

Endevco®

# Piezoresistive pressure transducer

## Model 8510C -15, -50, -100

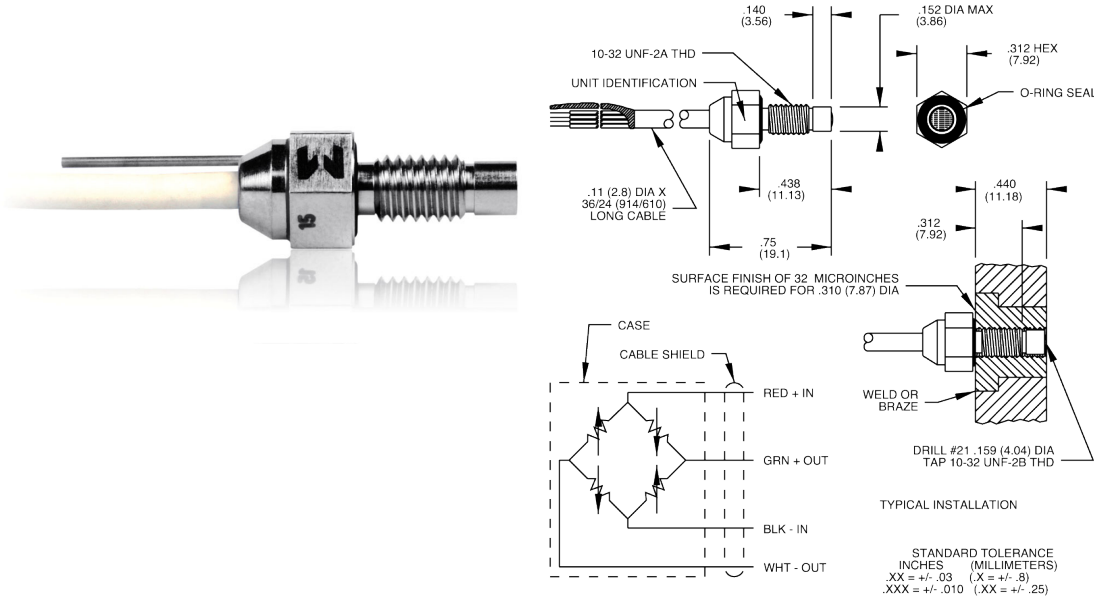

### Key features

- 15, 50 and 100 psig ranges
- 225 mV full scale output
- Rugged, miniature
- Gage

Model 8510C is a rugged, miniature, high sensitivity piezoresistive pressure transducer. Its high sensitivity combined with high resonance makes it ideal for measuring dynamic pressure. It has a 10-32 mounting thread, 0.15 inch (3.8 mm) face diameter and is available in ranges from 15 psi to 100 psi. The model 8510B is available for lower and higher pressure ranges.

Endevco pressure transducers feature a four arm strain gage bridge ion implanted into a unique sculptured silicon diaphragm for maximum sensitivity and wideband frequency response. Self-contained hybrid temperature compensation provides stable performance over the temperature range of 0°F to 200°F (-18°C to +93°C).

Endevco transducers also feature excellent linearity (even to 3X range), high shock resistance, and high stability during temperature transients.

8510C is designed for a wide variety of aerospace, automotive and industrial measurements which require a combination of small size, high sensitivity, and wideband frequency response. Typical applications include process control, jet engine inlet pressure measurements and wind tunnel flow measurements. Its vent tube may be connected to a standard reference manifold or used for differential pressure measurements.

Recommended electronics for signal conditioning and power supply are models 126 and 136 general purpose three channel conditioners, ultra low noise 4430A conditioner, or the 4990A-X (Oasis) multi-channel rack mount system.

## Meggitt Sensing Systems

### Our measurement product competencies:

Piezoelectric accelerometers | Piezoresistive accelerometers | Isotron accelerometers | Variable capacitance accelerometers | Pressure transducers | Acoustic sensors | Electronic instruments | Calibration systems | Shakers | Modal hammers | Cable assemblies

**MEGGITT**  
smart engineering for  
extreme environments

Endevco®

# Piezoresistive pressure transducer

## Model 8510C -15, -50, -100

### Specifications

The following performance specifications conform to ISA-RP-37.2 (1964) and are typical values, referenced at +75°F (+24°C) and 100 Hz, unless otherwise noted. Calibration data, traceable to National Institute of Standards and Technology (NIST), is supplied.

Dynamic characteristics	Units	8510C-15	-50	-100
Range [1]	psig	0-15	0-50	0-100
Positive sensitivity [2]	mV/psi typ (min)	15.0 (9.3)	4.5 (2.8)	2.25 (1.4)
Combined: non-linearity, non-repeatability, pressure hysteresis	% FSO RSS max	0.50	0.40	0.40
Non-linearity, independent	% FSO typ	0.15	0.1	0.1
Non-repeatability	% FSO typ	0.1	0.1	0.1
Pressure hysteresis	% FSO typ	0.1	0.1	0.1
Zero measurand output [3]	mV max	±20	±20	±20
Zero shift after 3X range	±% 3X FSO max (typ)	0.2 (0.02)	0.2 (0.02)	0.2 (0.02)
Thermal zero shift				
from 0°F to +200°F (-18°C to +93°C)	±% FSO max	3	3	3
Thermal sensitivity shift				
from 0°F and +200°F (-18°C to +93°C)	±% max	3	3	3
Resonance frequency	Hz	180 000	320 000	500 000
Non-linearity at 3X range	% 3X FSO	1.0	1.0	1.0
Thermal transient response per	psi/°F	0.003	0.003	0.01
ISA-S37.10, para. 6.7, procedure I [4]	psi/°C	0.005	0.005	0.02
Photoflash response [5]	Equiv. psi	0.1	0.3	0.6
Warm-up time [6]	ms	1	1	1
Acceleration sensitivity	Equiv. psi/g	0.00015	0.00015	0.00015
Burst pressure (diaphragm/reference side) [7]	psi min	75/300	250/300	400/300

### Electrical

Full scale output	225 mV typical (140 mV minimum) at 10.0 Vdc
Supply voltage [8]	10.0 Vdc standard, 15 Vdc maximum
Electrical configuration	Active four-arm piezoresistive bridge
Polarity	Positive output for increasing pressure into (+) port (end with screen on it)
Resistance	
Input	2600 ohms typical, 1700 ohms minimum
Output	1500 ohms typical, 2200 ohms maximum
Isolation	100 megohms minimum at 50 volts; leads to case, leads to shield, shield to case
Noise	5 microvolts rms typical, dc to 50 000 Hz; 50 microvolts rms maximum, dc to 50 000 Hz

### Mechanical

Case material	Stainless steel (17-4 PH CRES)
Cable, integral	4 conductor No. 32 AWG Teflon® insulated leads, braided shield, silicone jacket
Dead volume (+) port	0.0003 cubic inches (0.005 cc)
Mounting torque	10-32 UNF-2A threaded case 0.438 inch (11.12 mm) long/15 ±5 lbf-in (1.7 ±0.6 Nm)
Weight	2.3 grams (cable weighs 9 grams/meter)

### Environmental characteristics

Media [9]	
Temperature [10] [11]	-65°F to +250°F (-54°C to +121°C)
Vibration	1000 g pk
Acceleration	1000 g
Shock	20 000 g, 100 microsecond haversine pulse
Humidity	Isolation resistance greater than 100 megohms at 50 volts when tested per MIL-STD-202E, method 103B, test condition B

Endevco®

# Piezoresistive pressure transducer

## Model 8510C -15, -50, -100

### Calibration data supplied

Data supplied for all parameters in Certified Performance section. Optional calibrations available for all parameters in Typical Performance section.

### Accessories

Product	Description	8510C
EHR93	O-ring, Viton	Included
EHR96	O-ring, fluorosilicone	Optional
24328-3	4 conductor shielded cable, white	Optional

### Notes

- FSO [Full Scale Output] is defined as transducer output change from 0 psig to + full scale pressure. Calibration provided is for positive pressure. Sensitivity to negative pressures is typically within 1% of positive pressure sensitivity.
- 1 psi = 6.895 kPa = 0.069 bar.
- Zero Measurand Output (ZMO) is the transducer output with 0 psig applied.
- Significant higher thermal transient errors occur if the excitation voltage exceeds 10 Vdc. For sensitive phase change studies, many users reduce the excitation to 5 Vdc or even 1 Vdc.
- Per ISA-S37.10, Para. 6.7, Proc. I. The metal screen partially shields the silicon diaphragm from incident radiation. Accordingly, light incident at acute angles to the screen generally increases the error by a factor of 2 or 3.
- Warm-up time is defined as elapsed time from excitation voltage "turn on" until the transducer output is within  $\pm 1\%$  of reading accuracy.
- Note that the differential pressure on the diaphragm may not exceed the diaphragm pressure limit.
- Please specify the excitation voltage you will use and we will calibrate at that voltage for highest accuracy. See model definition.
- Internal seals are epoxy compatible with clean dry gas media. Media is exposed to CRES, ceramic, silicon, Parylene C, epoxy, silicone rubber, and the O-Ring. For use in water or corrosive media, contact the factory for modifications and installation precautions which may be taken to extend service life. Reference port media is restricted to clean, dry noncorrosive gases.
- Units can be compensated over any 200°F (93°C) span from -65°F to +250°F (-54°C to +121°C) on special order.
- O-Ring, EHR93 VITON is supplied unless otherwise specified on Purchase Order. EHR96 Parker material L677-70 for leak tight operation below 0°F (-18°C) is available on special order.
- Maintain high levels of precision and accuracy using Meggitt's factory calibration services. Call Meggitt's inside sales force at 800-982-6732 for recommended intervals, pricing and turn-around time for these services as well as for quotations on our standard products.

### Model definition

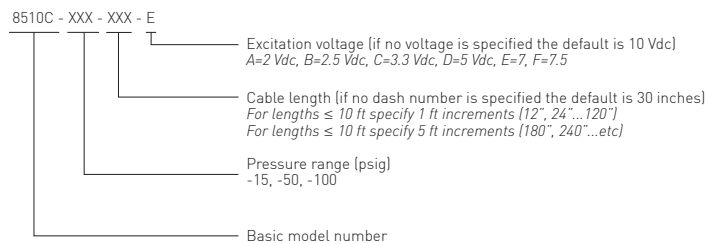

### Other options

- M1 No vent tube
- M2 No vent tube, no screen
- M4 Gel
- M5 Metric thread
- M7 No screen
- M8 "A" screen, black grease - ITAR
- M11 "B" screen
- M37 Integral connector, no vent tube, hole on side
- M41 No screen, gel

## Contact

### Meggitt Sensing Systems

14600 Myford Road  
Irvine  
CA 92606, USA  
Tel: +1 (949) 493 8181  
Fax: +1 (949) 661 7231

www.endevco.com  
www.meggitt.com



Continued product improvement necessitates that Meggitt reserve the right to modify these specifications without notice. Meggitt maintains a program of constant surveillance over all products to ensure a high level of reliability. This program includes attention to reliability factors during product design, the support of stringent Quality Control requirements, and compulsory corrective action procedures. These measures, together with conservative specifications have made the name Endevco synonymous with reliability. 3110414

**MEGGITT**  
smart engineering for  
extreme environments